

Ministry of Higher Education and Scientific Research

University of Baghdad

College of Science

Department of Biology



## practical Ecology

2022-2023

المرحلة الثالثة للدراسة الصباحية والمسائية

## مدرسوا المادة

أ.م.د. بهاء مالك  
أ.م. شيماء عبد الكريم  
م.د. ميادة خزعل  
م.د. زهراء علي  
م.د. ضحى زكي  
م.م. هند جبار  
م.م. لينة جعفر  
م.م. دنيا فلاح  
بايولوجي سامر اديب

أ.د. ايثار كامل  
أ.د. عادل مشعان  
أ.د. هند سهيل  
أ.د. احمد جاسم  
أ.م.د. احمد سعد  
أ.م.د. يعرب فالح  
أ.م.د. ندى عبد الرحمن  
أ.م.د. بيداء عبد القادر  
أ.م.د. محمود باسل

## **Lab.1**

### **Introduction to Practical Ecology**

Ecology is the study of an organism or organisms and their relationship to the environment. An organism's environment consists of the physical, chemical and biological components. Biotic factors (physical and chemical parameters) are the non-living components of the environment which include:

- Temperature
- Sunlight
- Water
- Wind
- Pressure
- Soil/substrate

- **Measurement of a biotic factors**

Biotic factors are easy to measure using simple instruments and equipment.

## First: Temperature measurements

Temperature is a physical property of matter that quantitatively expresses the common notions of hot and cold. Quantitatively, temperature is measured with thermometers, which may be calibrated to a variety of temperature scales. Most of the world uses the Celsius scale (°C) for most temperature measurements. A few countries, most notably the United States, use the Fahrenheit scale for common purposes, a historical scale on which water freezes at 32 °F and boils at 212 °F.

Some countries preferred the Kelvin scale in which water freeze at 273.15 and boils at 373.15 K.

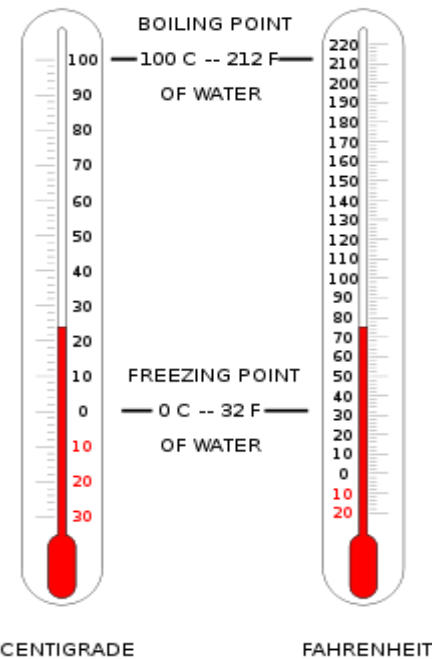

**For purpose to convert one temperature scale to another we can used the following equations**

<b>Convert Fahrenheit to Celsius</b>	$t_C = \frac{5}{9}(t_F - 32)$
<b>Convert Celsius to Fahrenheit</b>	$t_F = \frac{9}{5}t_C + 32$
<b>Convert Celsius to Kelvin</b>	$t_K = t_C + 273.15$
<b>Convert Kelvin to Celsius</b>	$t_C = t_K - 273.15$

# Practical Ecology 2022-2023

---

## Example 1

Convert 26° Celsius (*A nice warm day!*) to Fahrenheit

$$\textit{First: } 26^{\circ} \times 9/5 = 234/5 = 46.8$$

$$\textit{Then: } 46.8 + 32 = \mathbf{78.8^{\circ} F}$$

## Example 2

Convert 98.6° Fahrenheit (*Normal Body Temperature!*) to Celsius

$$\textit{First: } 98.6^{\circ} - 32 = 66.6$$

$$\textit{Then: } 66.6 \times 5/9 = 333/9 = \mathbf{37^{\circ} C}$$

## Example 3

Convert 27° C to Kelvin.

$$K = 27 + 273$$

$$K = 300$$

$$300 K$$

Temperature is commonly measured by using the different types of thermometers such as

### a. Liquid thermometer

An instrument for measuring temperature, often a sealed glass tube that has a column of liquid, as mercury, that expands and contracts, or rises and falls, with temperature changes, the temperature being read where the top of the column coincides with a calibrated scale marked on the tube or its frame of the most common kinds Alcohol thermometer and Mercury-in-glass thermometer.

## Practical Ecology 2022-2023

---

✓ **Liquid thermometer principle:** relation between temperature and volume of a liquid

✓ **How to use it**

1. Put the thermometer in the ground or water and leave for the heat to take effect.
2. Read the scale and carefully, wipe the thermometer and repeat a several times for the area.

### **b. Maximum and minimum thermometer**

✓ **The purpose of use**

Thermometer that records the highest and lowest temperatures reached during a period of time.

✓ **How maximum and minimum thermometers work?**

Maximum-minimum thermometers are typically U-shaped parallel tubes of glass. One side registers the minimum temperature, while the other registers the maximum temperature since its last reading. The bend at the bottom of the thermometer has the liquid mercury, which moves up and down based on contractions of the oil or alcohol located in the two bulbs at the top of the thermometer. The contractions of the alcohol or oil is the result of thermal changes in the environment causing it to expand or contract.

## Lab 2

### Second: Relative humidity

Relative humidity is **the ratio of the partial pressure of water vapor (in a gaseous mixture of air and water vapor) to the saturated vapor pressure of water at a given temperature**. Relative humidity is an important metric used in weather forecasts and reports, as it is an indicator of the likelihood of precipitation, dew, or fog. In hot summer weather, a rise in relative humidity also increases the temperature of the humans (and other animals) by hindering the evaporation of perspiration from the skin as the relative humidity rises. Relative humidity is often determined by using the following

#### a. Hair hygrometers

A **hygrometer** is an instrument used for measuring the moisture content in the atmosphere. Humidity measurement instruments usually rely on measurements of some other quantity such as temperature, pressure, mass or a mechanical or electrical change in a substance as moisture is absorbed. By calibration and calculation, these measured quantities can lead to a measurement of



humidity. Modern electronic devices use temperature of condensation (the dew point), or changes in electrical resistance to measure humidity differences.

Hair hygrometer works on the fact that hair changes its length when humidity varies. This device usually consists of a number of human or horse hairs connected to a mechanical lever system. When humidity increases the length of the hairs becomes longer. This change

## Practical Ecology 2022-2023

---

in length is then transmitted and magnified by the lever system into measurement of relative humidity.

### **b. Psychrometer**

A psychrometer or sling psychrometer is a device used to measure relative humidity. It has two thermometers. One thermometer is called a wet-bulb thermometer. The bulb of the wet-bulb thermometer is covered with a damp cloth. The sling psychrometer is whirled around, using the handle. As the instrument is whirled, water evaporates from the cloth on the wet-bulb thermometer and cools the thermometer. This value is known as the wet-bulb temperature. The drier the air the more quickly the thermometer cools and hence, the lower the wet-bulb temperature. If the humidity is high, only a small amount of water will evaporate and there will be little change in temperature. The other thermometer is a dry-bulb thermometer and measures air temperature. The difference in temperature reading between the wet-bulb and dry-bulb thermometers indicates the amount of water vapor in the air. A table like the one below is used to determine the relative humidity.

# Practical Ecology 2022-2023

Relative Humidity %

Dry Bulb Temperature (Celsius)	Difference Between Wet-bulb and Dry-bulb Temperatures (°C)															
	0	1	2	3	4	5	6	7	8	9	10	11	12	13	14	15
-20	100	28														
-18	100	40														
-16	100	48														
-14	100	55	11													
-12	100	61	23													
-10	100	66	33													
-8	100	71	41	13												
-6	100	73	48	20												
-4	100	77	54	32	11											
-2	100	79	58	37	20	1										
0	100	81	63	45	28	11										
2	100	83	67	51	36	20	6									
4	100	85	70	56	42	27	14									
6	100	86	72	59	46	35	22	10								
8	100	87	74	62	51	39	28	17	6							
10	100	88	76	65	54	43	33	24	13	4						
12	100	88	78	67	57	48	38	28	19	10	2					
14	100	89	79	69	60	50	41	33	25	16	8	1				
16	100	90	80	71	62	54	45	37	29	21	14	7	1			
18	100	91	81	72	64	56	48	40	33	26	19	12	6			
20	100	91	82	74	66	58	51	44	36	30	23	17	11	5		
22	100	92	83	75	68	60	53	46	40	33	27	21	15	10	4	
24	100	92	84	76	69	62	55	49	42	36	30	25	20	14	9	4
26	100	92	85	77	70	64	57	51	45	39	34	28	23	18	13	9
28	100	93	86	78	71	65	59	53	47	42	36	31	26	21	17	12
30	100	93	86	79	72	66	61	55	49	44	39	34	29	25	20	16

Step 1: Determine the temperature of the dry-bulb thermometer.

Step 2: Determine the temperature of the wet-bulb thermometer.

Step 3: Determine the difference in the wet-bulb and dry-bulb thermometer.

Step 4: Use the chart to determine the relative humidity.

What is the relative humidity?

%



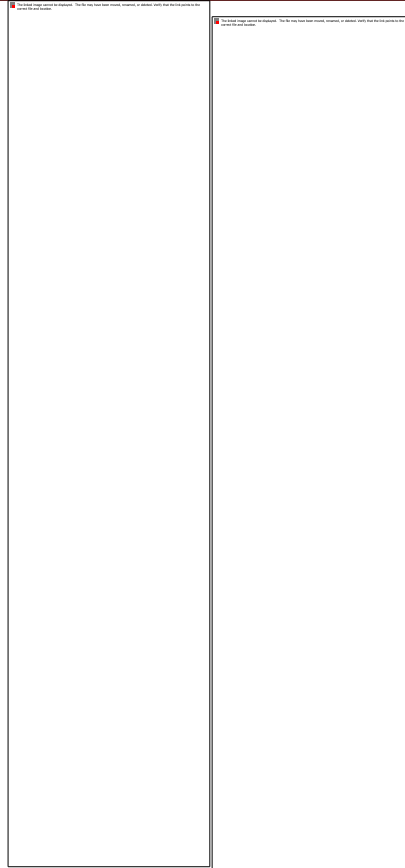

## c. Thermo-Hygrograph

A **Thermo-Hygrograph** is a chart recorder that measures and records both temperature and humidity (or dew point). Similar devices that record only one parameter are a **thermograph** for temperature and **hygrograph** for humidity. A thermograph usually configured with a pen that records temperature on a revolving cylinder. The pen located at the end of a lever which controlled by a bi-metal strip composed from temperature-sensitive metal which bends as the temperature changes.



### d. Thermo-hygrometer

The thermo hygrometer measures both humidity of the air and temperature of the air. The thermo hygrometer measures different ranges of humidity and temperature depending on the model. In modern thermo hygrometer is versatile in that it can take measurements, store them to memory and transfer data to a computer for further detailed analysis.

## Other instrument to measure indirect humidity

### I. Dew point apparatus

The Dew Point Apparatus consists of a closed stainless steel dew point chamber containing a highly polished stainless steel “target mirror” and sample inlet and outlet control valves. The chamber is chilled by refrigerant following through the outer cooling jacket, preventing any refrigerant contact with the test sample. The thermometer is inserted into the mirror support structure, providing the temperature of the “target mirror.” As the sample flows in the chamber and is deflected across the surface of the mirror, the temperature at which condensation collects on the mirror is recorded as the dew point of the sample.



## II. Rain gauge

A rain gauge (also known as a urometer or a pluviometer [Pluviograph ] is a type of instrument used by meteorologists and hydrologists to gather and measure the amount of liquid precipitation over a set period of time. The standard rain gauge, developed around the start of the 20th century, consists of a funnel attached to a graduated cylinder (2 cm in diameter) that fits inside a larger outside container (20 cm in diameter and 50 cm tall). If the water overflows the inside graduated cylinder, the outside larger container will catch it. When measurements are taken, the height of the water in the small graduated cylinder is measured and the excess overflow in the large container is carefully poured into another graduated cylinder and measured to give the total rainfall.

## **Lab 3**

### **Third: Atmospheric pressure**

## Practical Ecology 2022-2023

---

**Atmospheric pressure**, sometimes also called barometric pressure, is the pressure exerted by the weight of air in the atmosphere of Earth . Low pressure areas have less atmospheric mass above their places, since high pressure areas have more atmospheric mass above their sites. We can measure the pressure by the following

### a. Barometer

A barometer is a scientific instrument used in ecology to measure atmospheric pressure. It can measure the pressure exerted by the atmosphere by using water, air, or mercury. Numerous measurements of air pressure are used such as Water-based barometers, Mercury barometers and aneroid barometer.

### b. Barograph

A barograph is a recording aneroid barometer. It produces a paper or foil chart called a **barogram** that records the barometric pressure over time. Barographs use one or more aneroid cells acting through a gear or lever train to drive a recording arm that has at its extreme end either a scribe or a pen. The recording material is mounted on a cylindrical drum rotated slowly by clockwork.

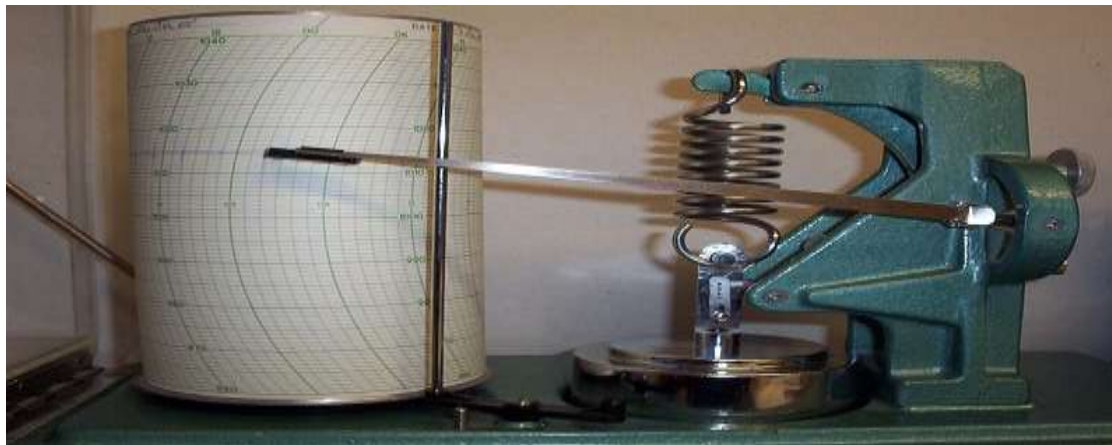

## Fourth: Density

## Practical Ecology 2022-2023

---

The mass density or density of a material is defined as its mass per unit volume. In some cases density defined as its weight per unit volume. This quantity is more properly called specific weight. Different materials usually have different densities, so density is an important concept to express the buoyancy, purity and packaging.

Less dense fluids float on more dense fluids if they do not mix. This concept can be extended, with some care, to less dense solids floating on more dense fluids. If the average density (including any air below the waterline) of an object is less than water ( $1000 \text{ kg/m}^3$ ) it will float in water and if it is more than water's it will sink in water.

The mass density of a material varies with temperature and pressure. (The variance is typically small for solids and liquids and much greater for gasses.) Increasing the pressure on an object decreases the volume of the object and therefore increase its density. Increasing the temperature of a substance (with some exceptions) decreases its density by increasing the volume of that substance.

### a. Hydrometer

A **hydrometer** is an instrument used to measure the specific gravity (or relative density) of liquids; that is mean, the ratio of the liquid density to the density of water.

- **The principle**

The basic principle of the hydrometer based on **Archimedes' principle** that *The buoyant force applied to an object is equal to the weight of the fluid the object displaces*. Thus, the lower the density of the substance, the farther the hydrometer will sink.

- **The consists**

A hydrometer is usually made of glass and consists of a cylindrical stem and a bulb weighted with mercury or lead shot to make it float upright. The tested liquid poured into a tall container, often a graduated cylinder, and the hydrometer is gently lowered into the liquid until it floats freely. Hydrometers usually contain a scale inside the stem, so that the specific gravity can be read directly. A variety of scales exist, and are used depending on the

## Practical Ecology 2022-2023

---

context. Hydrometers may be calibrated for different uses, such as a lactometer for measuring the milk density, a saccharometer for measuring the sugar density in a liquid, or an alcoholmeter for measuring higher levels of alcohol in spirits.

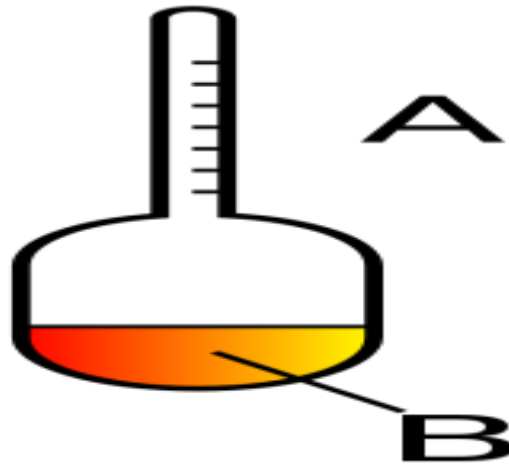

### **Fifth: Wind speed**

**Wind speed** usually mean, movement of air in an outside environment. The wind speed are commonly measured by the following

#### **a. Anemometer**

**Anemometer** is a device for measuring wind speed, and is a common weather station instrument. The term is derived from the Greek word *anemos*, meaning wind, and is used to describe any airspeed measurement instrument used in meteorology or aerodynamics. The first known description of an anemometer was presented around 1450. Anemometers can be divided into two classes: those that measure the wind's speed, and those that measure the wind's pressure; but because of close relationship between the pressure and the speed, some anemometers designed for one will give information about both.

### ✓ Cup anemometers

A simple type of anemometer consisted of four hemispherical cups each mounted on one end of four horizontal arms, which in turn were mounted at equal angles to each other on a vertical shaft. The air flow passing the cups in any horizontal direction turned the cups in a way that was proportional to the wind speed. Therefore, counting the turns of the cups over a set time period produced the average wind speed. On an anemometer with four cups it is easy to see that since the cups are arranged symmetrically on the end of the arms, the wind always has the hollow of one cup presented to it and is blowing on the back of the cup on the opposite end of the cross.

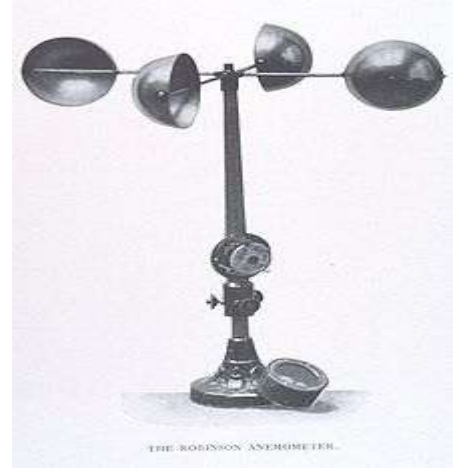

## Lab 4

- **Other instruments and devices are used in ecology for different purpose**

### 1. Van Dorn water sampler

The horizontal water sampler is intended for taking water samples near the bottom in lakes, streams, or in stratified water bodies. The water sampler is based on the Van Dorn design. The sampler is made of sturdy transparent PVC (plastics) and has a double releaser, activated by a drop messenger.



### 2. Ekman Bottom Grab Samplers

The Ekman Bottom Grab sampler is designed for sampling in soft bottomed lakes and rivers composed of clay, mud or fine peat. As the sampler is lowered, two hinged upper lids swing open to let water pass through and close upon retrieval preventing sample washout. When the sampler reaches the bottom, a messenger is sent down the line tripping the loaded scoops (Scoops overlap to reduce sample loss).



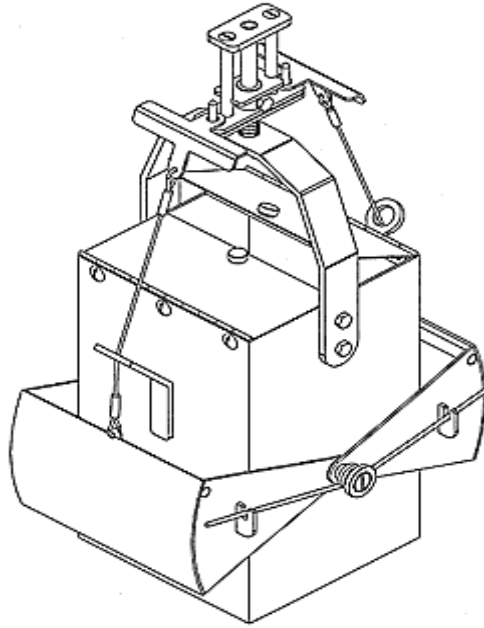

### 3. pH meter

A **pH meter** is an electronic instrument used for measuring the pH (acidity or alkalinity) of a liquid (though special probes are sometimes used to measure the pH of semi-solid substances). A typical pH meter consists of a special measuring probe (a glass electrode) connected to an electronic meter that measures and displays the pH reading.

#### ✓ **Calibration and use**

For very precise work the pH meter should be calibrated before each measurement. For normal use calibration should be performed at the beginning of each day. Calibration should be performed with at least two standard buffer solutions that span the range of pH values to be measured. For general purposes buffers at pH 4 and pH 10 are acceptable.

### 4. Sunshine recorder

A **sunshine recorder** is a device that records the amount of sunshine at a given site. The results provide information about the weather and climate of a geographical area. This information is useful in meteorology, science, agriculture, tourism, and other fields. There are



two basic types of sunshine recorders. One type uses the sun itself as a times scale for the sunshine readings. The other type uses some form of clock for the time scale.

Older recorders required a human observer to interpret the results; recorded results might differ among observers. Modern sunshine recorders use electronics and computers for precise data that do not depend on a human interpreter. Newer recorders can also measure the global and diffuse radiation.

### 5. The Secchi disk

The **Secchi disk**, created in 1865 by Pietro Angelo Secchi , it is a circular disk used to measure water transparency in oceans and lakes. The disc is mounted on a pole or line, and lowered slowly down in the water. The depth at which the pattern on the disk is no longer visible is taken as a measure of the transparency of the water. This measure is known as the **Secchi depth** and is related to water turbidity.

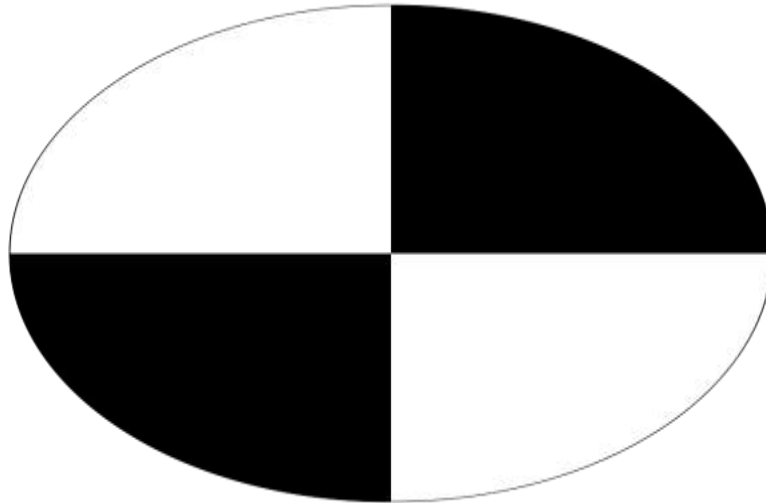

The Secchi depth reached the depth inside the water when the reflectance could equal to the intensity of backscattered light. A Secchi disk measurement should always be taken off the shady side of a boat or dock between 9 a.m. and 3 p.m. The period for best results is between 10 am and 2 pm. The same observer should take Secchi depth measurements in the same procedure every time. One can approach the measurement by lowering the disk beyond a point of disappearance, then raising it and lowering it slightly to set the Secchi depth. Another method is to record the depth at which the disk disappears, lower another few feet, then record the depth at which the disk reappears as it is slowly brought up. The Secchi depth is taken as the average of the two values.

## Lab5

### 6. Turbidity and nephelometer

Turbidity is the cloudiness of a fluid caused by small particles (suspended solids) that are generally invisible to the naked eye, similar to smoke in air. The turbidity measurement is the key test of water quality.

Fluids can contain suspended solid matter consisting of particles of many different sizes. While some suspended material will be large enough and heavy enough to settle rapidly to the bottom of the container if a liquid sample is left to stand (the settling solids), very small particles will settle only very slowly or not at all if the sample is regularly agitated or the particles are colloidal. These small solid particles cause the liquid to appear turbid.

A **nephelometer** is stationary or portable instrument for measuring suspended particulates in a liquid or gas colloid. A Nephelometer measures suspended particulates by employing a light beam (source beam) and a light detector set to one side (often 90°) of the source beam. Particle density is the function of the light reflected into the detector. Because optical properties depend on suspended particle size, a stable



synthetic material called "Formazin" with uniform particle size is often used as a standard for calibration and reproducibility. The unit is called Formazin Turbidity Units (FTU). Nephelometric Turbidity Units (NTU) specified by United States Environmental Protection Agency.

## 7. Electrical conductivity

An electrical conductivity meter (EC meter) measures the electrical conductivity in a solution. **Conductivity** is one way to measure of the inorganic materials including calcium, bicarbonate, nitrogen, phosphorus, iron, sulphur and other ions dissolved in a water body. It is measured by placing a conductivity probe (EC instrument) in the sample and measuring the flow of electricity between the electrodes. Conductivity is measured with a meter in micro Siemens per centimeter units ( $\mu\text{S}/\text{cm}$ ). The probe (EC instrument) consists of a tube, usually of plastic, into which electrodes have been installed. Two common electrode arrangements are: 1) two plates; or 2) a rod located concentrically in a ring. When the probe is immersed in the solution, ions contained in the solution will produce an electrical flow from one electrode to another. If a many ions are present (salty conditions), then the EC of the sample will be higher than a sample with low number of ions (low salts).

## 8. Spectrometer (spectrophotometer, spectrograph or spectroscope)

A spectrometer is an instrument used to measure properties of light over a specific portion of the electromagnetic spectrum, typically used in spectroscopic analysis to identify materials. A spectrometer used in spectroscopy for producing spectral lines and measuring their wavelengths and intensities. Spectrometer is a term that is applied to instruments that operate over a very wide range of wavelengths, from gamma rays and X-rays into the far infrared.

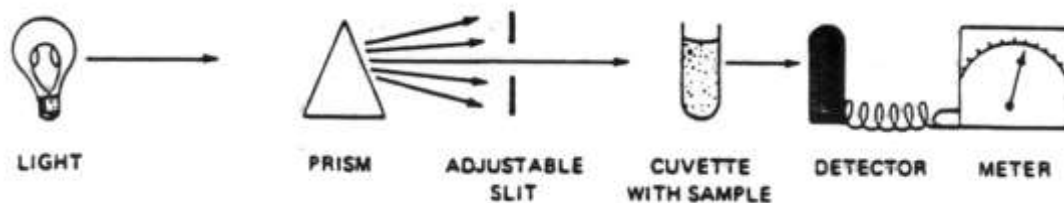

*A diagram showed the main parts of the Spectrometer*

## ✓ **How Spectrophotometer Work ?**

A Lamp provides the source of light. The beam of light strikes the diffraction grating, which works like a prism and separates the light into its wavelength components. The grating, is rotates so that only a specific wavelength of light reaches the exit slit. Then the light interacts with the sample (cuvette with sample). From this point, the detector measures the transmittance and absorbance of the sample. Transmittances refers to the amount of light that pass throw the sample and strikes the detector. A measurement Absorbance is the light absorbed by the sample. The detector senses the light being transmitted through the sample and converts this information into a digital display.

## **9. Atomic absorption spectroscopy (AAS)**

Atomic absorption spectroscopy (AAS) is a spectro-analytical procedure for the qualitative and quantitative determination of chemical elements. The technique is employing the absorption of optical radiation (light) by free atoms in the gaseous state. In ecology the technique used to detect the particular element concentration for the analyzed samples. AAS can be used to determine over 70 different elements in solution or directly in solid samples.

## **10. Global positioning System (GPS)**

The global positioning system (GPS) is a satellite-based system that can be used to find the positions anywhere on earth. It's continuously transmitted coded information, which makes it possible to precisely detect the position on earth by measuring distance from the satellites.

The GPS provides continuous (24hr/day), real-time, 3-dimentional positioning, navigation and timing

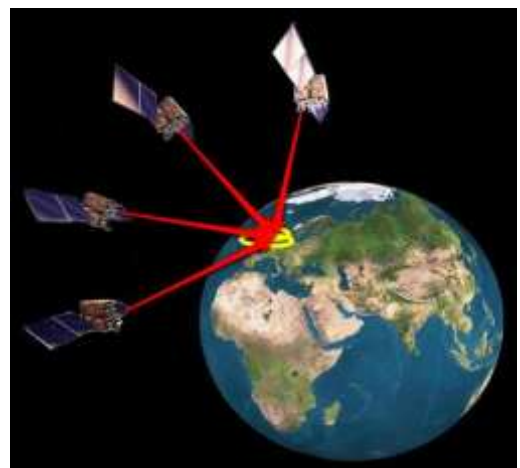

## Practical Ecology 2022-2023

---

worldwide. The Global Positioning System is a constellation (or set) of at least 24 satellites that continuously transmit faint radio signals toward the earth. The radio signals carry the satellite position information. The special codes allow anyone has a GPS receiver measure the distance from his place to the satellite. Our site on the earth is calculated by measuring our distance from a group of satellites in space. This calculation is done by timing how long it takes a radio signal to reach us from a particular satellite.



### 11. Remote sensing

Remote sensing is the technique used to learn the nature of ecosystems and the environment without direct contact. These methods involve the use of electromagnetic and sound waves ,radiant energy and ionizing radiation. One method of remote sensing uses aerial photography. Black and white stereoscopic photos are used to find the volume of timber stand, to count wild animals, to record vegetation and man-made changes in the landscape and to prepare topographic maps. More recently, the colored photography has been widely employed with visual contrast help us to identify the tree species, insect damage, plant disease, and details of aquatic environment.

Infrared photography is a newer and very useful technique in the study of vegetation because the molecules of pigments in plant do not absorb infrared wavelengths. Instead the infrared is either transmitted through the leaves or is reflected by the cell walls. One species Plant Cells have a more different reflectivity than abnormal ones. There for, infrared photography has been used to distinguish species in addition to detect unhealthy plants. It is

also used to detect differences in environmental temperature. Such pictures or thermographs which have differences in temperature will appear as contrasting bands. These colored bands of used in the thermal pollution detection.

### **Lab.6**

## **Sampling in Ecology**

It is an absolute necessity that one attempts to collect samples that are representative of the matrix under investigation. When collecting samples, one must follow predetermined sampling protocols (procedures and methods) which have been chosen (bearing in mind the sampling (collection) site, the number of samples to be collected, and the timing of the sampling) to meet the purpose of the survey, and which are proper to the media being investigated.

### **1. Water quality sampling**

#### **1.1 Sampling timing**

Time the sampling trip such that it is possible to collect a representative water sample from the designated sampling point. Take into account factors such as the weather, tides, currents, geography etc.

#### **1.2 Sampling point**

For rivers, the primary sampling point is in the surface water layer (0-5 cm from the surface) at the centre of the main flow. However, the top 1-2 cm of this surface layer should be avoided so as not to collect floating dust, oil, etc. In addition, further samples can be collected through the full depth of the water column if required to meet the purpose of the study.

For lakes and the ocean, the sampling point will be selected after taking into consideration such factors as geography, whether there are freshwater (rivers or streams) or wastewater inflows, depth, tides, currents etc. Two different types of sample can be taken from rivers, lakes and similar surface waters. The simplest, a “grab” sample, is taken at a selected



location, depth and time. Normally, the quantity of taken water is sufficient for all the physical and chemical analyses that will be done on the sample.

For underground water, the sampling site or sites will be selected after taking into consideration such factors as water flow and geological structure (hydrogeology), and also site conditions such as factories or land use, and avoiding bias so as to be able to understand the whole area's underground water.

### **1.3. Sampling tools and containers**

The type of water sampling tool required will depend on the sampling site and the type of sample to be taken. Sampling can be achieved using buckets, open water grab samplers, or vertical and horizontal messenger activated samplers (such Niskin bottles). The type of material such tools should be made of will depend on the purpose (target analytes) of the study, but relatively inert materials such as stainless steel, synthetic resin such as polypropylene, polyethylene or pertetrafluoroethylene (PTFE), or glass are all acceptable. The size and type of sample to be taken will determine the type of sample container required.

- For volatile organic compounds, use clear or brown bottles or vials with screw caps or stoppers lined with tetrafluoroethene resin films.
- For semi-volatile or non-volatile organic compounds, use clear or brown glass jars with a stoppers or Teflon lined screw caps.
- For inorganic compounds such as heavy metals, use polyethylene containers

### **1.4 Sampling operation**

Collect the water sample using the most appropriate sampling tool given the nature of the sampling site, the target analyte, and the instrument on which quantitative measurement will be performed. Sample containers should be washed 3-4 times with water from the exact site of sampling before taking the sample. The samples should be carefully and gently poured into its container without making bubbles.

- For volatile organic compounds, sample containers should be completely filled with bubble-free water and sealed tight.

# Practical Ecology 2022-2023

---

- For semi- and non-volatile organic compounds, sample container should be completely filled with water that is as free as possible of air bubbles.
- For inorganic compounds such as heavy metals, the container should be approximately 80-90 % filled with the water sample (the space above the surface of the water sample allows thorough mixing just before analysis).

## 1.5 Field records

On a form which has been prepared in advance, record all pertinent details e.g. the sampling date, sample name (code), sampling site's name (code), an accurate position for the sampling site (map of G.I.S. position), general environmental conditions such as the nature of the surrounding

landscape, the state of the tide or river flow, weather conditions such as cloud cover and air temperature, and general water conditions such as colour, water temperature, pH, and dissolved oxygen content, etc.

## 1.6 Labeling of samples

Label each sample unambiguously, i.e. write on the sample bottle in water-resistant ink details of the name or code of the sample, the sampling date, the sampling site name etc. Finally, record on each sample and in the field record details of transport methods, storage methods, etc.

## 1.7 Transport and storage of samples

Procedures for handling the sample during transport will depend on the nature of the sample matrix and the target analytes. However, ideally all samples should be cooled in ice soon after collection, and then transported to the laboratory packed in ice. If samples must be stored for any significant period of time, refrigerate or freeze samples as soon as possible after collection or arrival at the laboratory.

## 2. Plants Sampling

The actual recording of the plant community is done by the use of small sampling units. These units may be in the form of area, line, or point, as has been employed in the quadrat, transect, and point sampling methods, respectively as follows:

# Practical Ecology 2022-2023

---

## **2.1 Quadrature method.**

It is a technique which is used when only a part of a large area is sampled. On the basis of this information, the total population of the area is estimated. For example, if we want to know the number of pine trees in a forest, we can make a total count, but this may be too much time consuming, difficult and expensive. Instead, if we count the trees in several blocks of squares (Quadrates) of the forest and by extrapolating these results for the whole forest area, we can make an estimate of the total number of trees. The quadrature method is used to measure the population density of organisms such as plants, planktons, earth worms, insects and also blood cell in the blood.

## **2.2 Transect method**

A transect is across section of an area used as a sample for recording, mapping, or studying vegetation. Because of its continuity through an area, the transect can be used to relate changes in the environment. Line transect method is commonly used for sampling of the forest and it consists of taking observations on a line or lines laid out randomly or systematically over the study area.

## **Lab 7**

### **3. Animal Populations Sampling**

The ecological study of animal populations in the ecosystem involves considerably more problems than the study of plants. Animals are harder to see and most are not stationary—they are here one minute and gone the next. The following methods give valuable information's regarding animal populations of different kinds:

#### **3.1 Trapping and collecting animals:**

The sampling of a population involves collecting animals, either alive for marking and release, or dead. For different types of animals different techniques are adopted which are as follows:

##### **(I) Trapping and collecting flying insects:**

Aerial nets or heavy nets when put through grass and woody vegetation, are used for the collection of diurnal insects. For nocturnal insects, traps containing ultra-violet light are used. Insects then picked off the sheet. For killing the insects, killing jars containing a layer of plaster of paris and potassium cyanide (KCN) on the bottom are used.

##### **(II) Trapping and collecting aquatic organisms:**

For collecting aquatic organisms are used nets for organisms in the water bottom, and plankton nets for zooplanktons and phytoplankton. For aquatic collecting from the shore, aquatic throw nets are useful. For collecting bottom organisms in deep water, is used a

## Practical Ecology 2022-2023

---

bottom dredge (bag net) lowered from a boat. Fish, and large crustacean collected with seines (large vertical fishing-nets).

### **(III) Trapping and collecting soil organisms:**

Different animals of soil are collected by following methods: Soil arthropods are extracted from the soil by means of a Tullgren funnel, an improved version of the Berlese funnel. It consists of a heat source and a smooth funnel, preferably glass, and a shelf of hard-ware cloth on which to place the sample.

Larger soil animals like spiders and beetles, can be taken in traps made from funnels and cans set in the soil to ground level. Boards placed on the ground may attract millipedes, centipedes and slugs. Meat bait in small wire traps will attract scavenger insects.

For the collection of earthworms, a dilute solution of formalin (25 ml of 40 per cent formalin to 4 541 litres) is applied to a quadrat 61 cm<sup>2</sup>. Within a few minutes worms will come to the surface. After earthworm movement to the surface stops, a second application of dilute formalin solution is done.

When worms stop to come to the surface the second time, the quadrat is dig out as deep as necessary. The soil is hand-sorted for maximum recovery of earthworms. Soil nematodes can be collected by Tullgren funnel method .

### **(IV) Trapping and collecting birds and mammals:**

Birds can be trapped for banding in specially constructed traps, cannon nets for larger game birds, and mist nets. For mammal live traps of wood or wire and snap traps are used. These traps can be baited with natural foods, dripping water, etc.

### 3.2 Marking animals:

Marking individuals in an animal population is necessary if one wishes to distinguish certain members of a population at some future date, to recognize individuals from their neighbours, to study movements or to estimate number of animals in a population.

Arthropods and snails are best marked with a quick-drying cellulose paint. Aquatic insects and molluscs are marked by ship-fouling paint.

Fishes are usually marked by tagging in several ways. Strap tags of Monel metal (a nickel-base alloy) may be attached to the jaw, the operculum. Streamer or pennant (a long narrow flag) tags are sometimes attached to various parts of body, usually at the base of the dorsal fin. A plastic tag can be inserted into the body cavity of fish by performing a minor operation. Fish can also be marked by clipping the fins.

Frogs, toads, salamanders and most lizards can be marked by some system of toe clipping which involves the removal of the distal part of one or more toes. Birds are usually marked either by serially numbered aluminium bands, by cellulose and aluminium coloured bands or by dyeing plumage by conspicuous or contrasting colour.

Small mammals may be marked by toe-clipping or by notching the ear. Bear, deer, elk, moose, rabbits and hares can be marked with strap tags or plastic discs attached to the ear. Aluminium bands similar to those used on birds can be attached to the forearm of bats.

#### ✓ **Radioactive tracers:**

The use of radioactive tracers in marking of animals, is a particularly useful method for studying animals that are secretive in habits, live in dense cover, spend part or all of their lives underground, or that have radically different phases in their life cycle, such as moths and butterflies.

It is found that if animals are fed small traces of gamma-emitting radioactive material along with food, then the radio-active materials are metabolically incorporated into the tissues. The tracer becomes a part of the animal and is passed along to egg or offspring. This technique is useful for studying dispersal and for the identification of specific broods or litters in addition to get data on population dynamics and natural choice.

### **3.4 Estimation of number of animals in population:**

The numbers of animals in wild populations can be estimated by following three methods: 1. True census, a count of all individuals in a given area; 2. Sampling estimates, derived from counts on sample plots; and 3. Indices, in which the trends of populations from year to year or from area to area are obtained through roadside counts, animal signs, and the like.

#### **(a) True census:**

A true census implies a direct count of all individuals in a given area. Direct counts can be made only in large a conspicuous animals and in areas of their maximum concentration. Elephants, deer, etc., in open country, herds of elk, waterfowl on wintering grounds, rookeries, roosts, breeding colonies of birds and mammals permit direct counting usually either from the air or from aerial photographs.

#### **(b) Estimates from sampling:**

This involves following methods:

##### **(i) Sample plots:**

Relatively immobile forms such as barnacles and molluscs can be estimated by the quadrature method, similar to that used for plants. Arthropods may be sampled by a number of strokes with a standard sweep over a  $10 = \text{m}^2$  area. Estimates of zooplankton, obtained by pulling plankton net through a given distance of water at several depths, can be made by filtering a known volume of sample through a funnel using a filter pump.

## Practical Ecology 2022-2023

---

The filter paper is marked off in equal squares and by the help of a hand lens or a binocular microscope, the organisms in each square are counted. The numbers are then related back to the total volume of water sampled.

Very small-sized zooplanktons are counted by Rafter plankton- counting cell. This consists of a microscope slide base plate ruled into ten 1 cm squares.

### **(ii) Mark-recapture method:**

In this method, a group of animals in the population are captured and marked with a band or tag for some time. Then they are released back into the population, where they are distributed among unmarked individuals. Later another group of animals is captured, some of which will be marked and some of which are not.

The ratio of marked animals to the number in the sample is assumed to be similar to the ratio of the total animals initially marked to the total number of animals in the entire population.

### **(iii) Removal method:**

This method involves capturing animals and removing them from the study area. If this technique is used over a short time, the number of animals removed per unit effort should get smaller and smaller.

By totaling the accumulative catch through time, it is possible to estimate the number in the area, even though we only remove some of the animals. This method is useful where one desires a relative measure or index figure for small-mammal populations to compare one habitat with another.



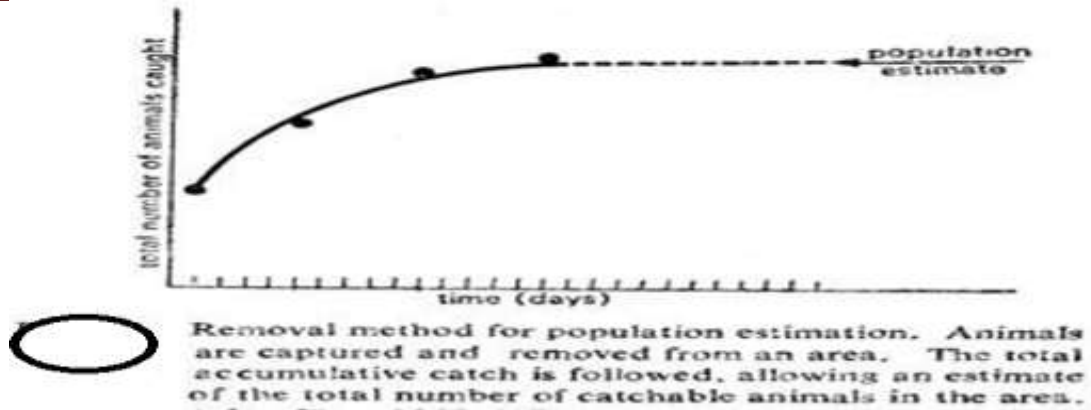

## Lab.8

### Soil sampling and textures

#### A. Soil Sampling Methods

Collecting soil samples is the most important step in any ecological study. The sample should represent the area it is taken from. A soil sample must be taken at the right time and in the right way. The tools used, area sampled, depth and uniformity of the sample, information provided, and packaging all influence the quality of the sample.

#### ✓ Correct Sampling Time

- Take a soil sample a few months before initiating any new human activities.

# Practical Ecology 2022–2023

---

- If an established area exhibits abnormal growth or plant discoloration, take a soil sample right away. You may want to submit matching plant tissue samples or separate soil samples for nematode assay. For areas recently limed or fertilized, delay sampling at least six to eight weeks.

## ✓ **Types of soil sampling**

Fields can be broken into either zones or grids when developing a soil sampling plan. Within those zones or grids, soils can either be taken randomly or sampled at or near the intersections. Soil test values from random and grid sampling are often used to provide a single estimate for an entire field.

### **1. Random Sampling**

Uniform fields can be randomly sampled throughout the entire field. To see long-term trends in soil nutrient data, these points should be georeferenced with a global positioning system (GPS) receiver and sampled in these same locations in subsequent years.

### **2. Grid Sampling**

Grid sampling can be particularly useful where there is little prior knowledge of within-field variability. It also avoids sampling bias that could result from the collection of an unrepresentative composite sample due to a high portion of subsamples collected from the same region. Two common types of grid sampling include grid-cell and grid-point. Grid-cell soil sampling randomly collects either one or multiple subsamples throughout the cell for a composite sample. Grid-point soil sampling collects one or multiple subsamples around a geo-referenced point within a grid or at a grid intersection.

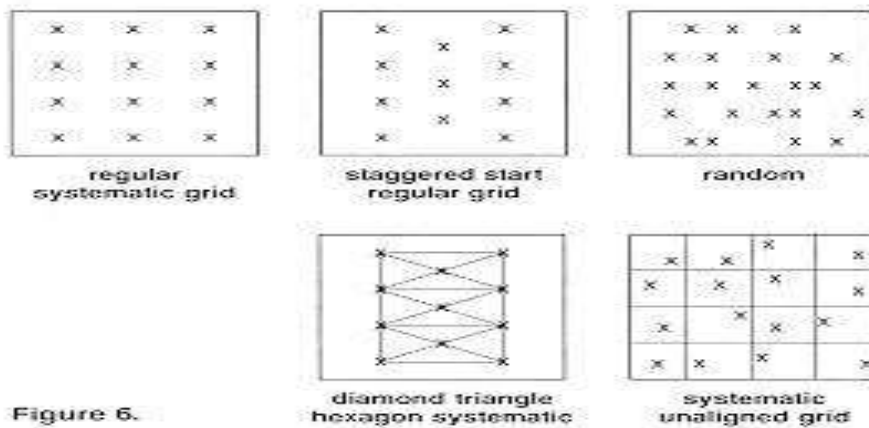

Figure 6.

### 3. Zone Sampling

Zone sampling is a soil sampling technique that assumes that each field contains different soils with unique soil properties and crop characteristics, and therefore should be separated into unique zones of management. For example, regions of fields that have had different crop history, yield or fertilizer treatments, and/or that vary substantially in slope, texture, depth and/or soil color should be separately sampled and therefore established as a zone. Unlike grid sampling, the number of zones and their shape and size will depend on the degree of field variability. In addition, zone sampling reduces the number of soil samples compared to grid or random sampling.

#### ✓ Use Clean Sampling Equipment

- Use a soil-sampling probe or an auger
- Tools should be either stainless steel or chrome-plated. Do not use brass, bronze, or galvanized tools because they will contaminate samples with copper and/or zinc.
- If a spade is used, dig a V-shaped hole to sample depth then cut a thin slice as shown on the figure below.
- Mix soil cores for each sample in a clean, plastic bucket. If the bucket has been used to hold fertilizer or other chemicals, wash it thoroughly before using it for soil samples.

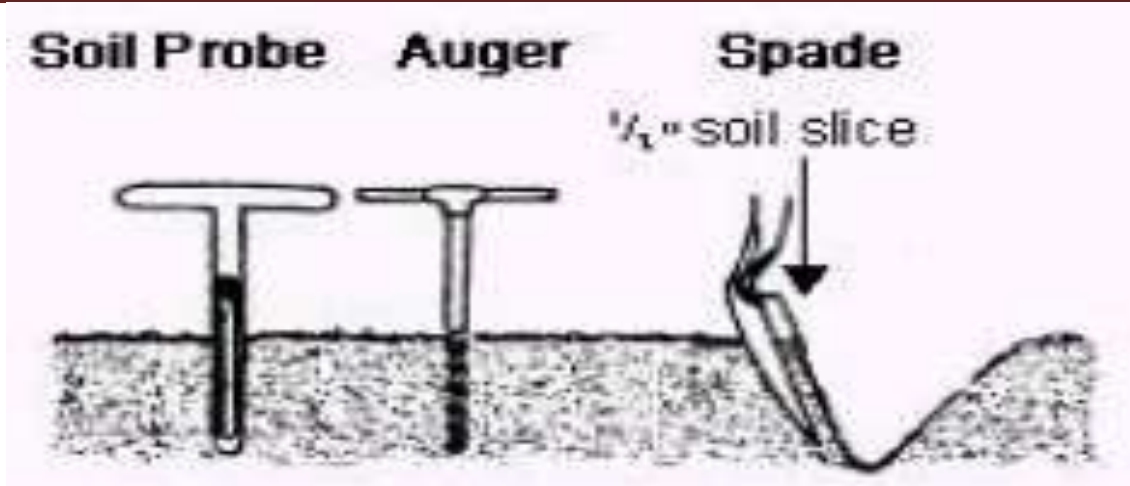

## ✓ Sampling Area

- Each sample should represent only one soil type or area—for example, a lawn, vegetable garden or perennially landscaped area. For each unique area, take at least six to eight samples. Place all the samples for one unique area in a plastic bucket and mix thoroughly. Use the mixture in the bucket to fill a soil sample bag about two-thirds full. Look for the fill line on the bag.

## ✓ Submitting Samples

- Put samples in sample bags
- Use a ballpoint pen or water proved marker to label each sample bag and complete the soil submittal form. Bags labeled with a pencil can be very difficult to read if they become dirty.

## Practical Ecology 2022–2023

---

- *Do not* put information sheets inside sample bags. Attach information sheets to the outside of the shipping bag or put them inside the shipping box next to or on top of the samples.

### **B. Soil texture**

Soil normally consists of rocks and minerals (about 45%), water (25%), air (25%), and organic matter (5%). The primary inorganic material is in turn composed of three primary particles—sand, silt, and clay. The differences in the size of the particles are due to the weathering of the parent rock. Soil texture is an important indicator of the ability of soil to absorb and hold both water and plant nutrients and which affects many of the physical and chemical properties of the soil.

#### ✓ **Soil textural classes**

Texture refers to the size of the particles that make up the soil. The terms sand, silt, and clay refer to relative sizes of the soil particles. Sand, being the larger size of particles, feels gritty. Clay, being the smaller size of particles, feels sticky. It takes 12,000 clay particles lined up to measure one inch. Silt, being moderate in size, has a smooth or floury texture. The combined portions of sand, silt, and clay in a soil determine its textural classification.

-Sand particles range in size from 0.05–2.0 mm,

- Silt ranges from 0.002–0.05 mm,

-Clay fraction is made up of particles less than 0.002 mm in diameter. Gravel or rocks greater than 2 mm in diameter are not considered when determining texture.

#### ✓ **Soil Texture Triangle**

The *soil texture triangle* gives names associated with various combinations of sand, silt and clay. A *coarse-textured* or *sandy* soil is one comprised primarily of sand-sized particles. A *fine-textured* or *clayey* soil is one dominated by tiny clay particles. Due to the strong physical properties of clay, a soil with only 20% clay particles behaves as sticky, gummy

## Practical Ecology 2022-2023

clayey soil. Once the sand, silt, and clay percentages of a soil are known, the textural class can be read from the textural triangle. For example, a soil with 40% sand, 40% silt and 20% clay would be classified as a loam. The term *loam* refers to a soil with a combination of sand, silt, and clay sized particles. Also, a soil with 30% clay, 50% sand, and 20% silt is called a *sandy clay loam*.

### ✓ Using the Soil Texture Chart

To determine the texture class of a soil, you will first determine the % sand, silt, and clay in the sample.

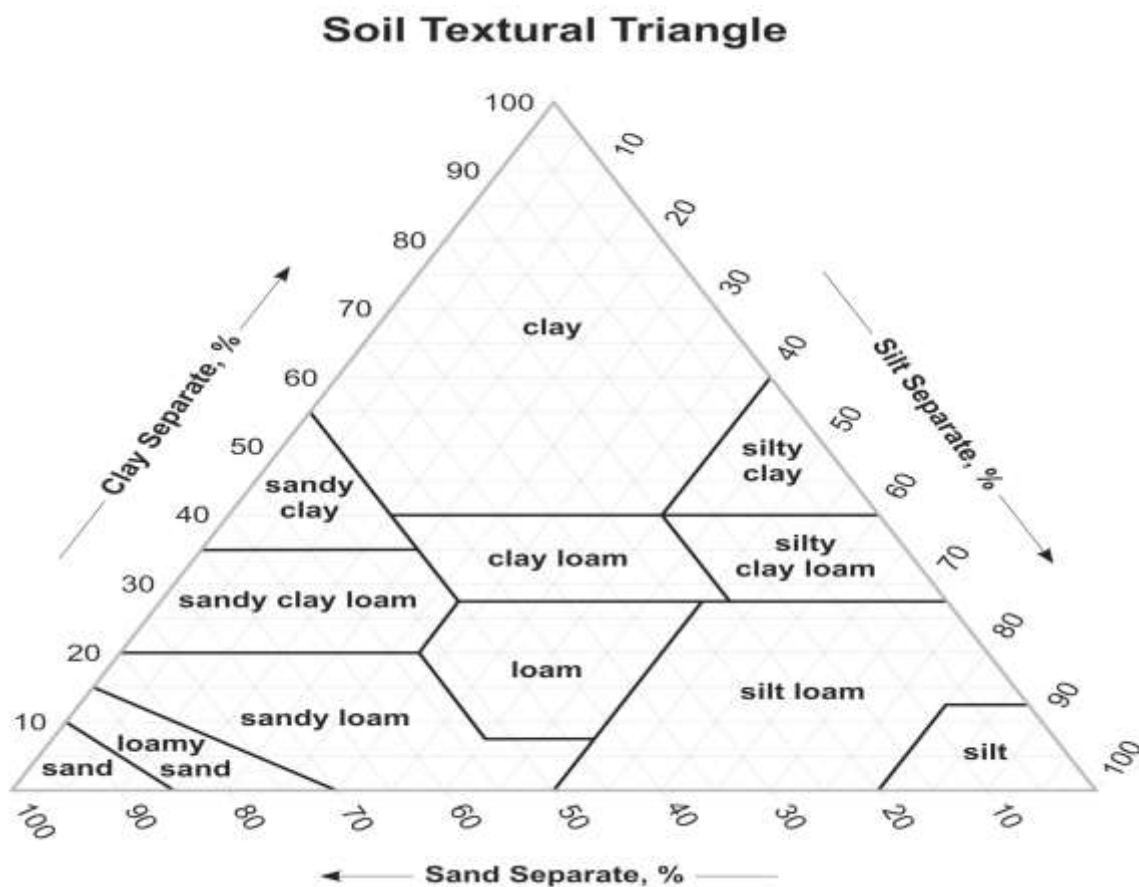

To read the triangular chart draw lines from points on each axes that correspond to the values you obtained from mechanical analysis. Please consult with your instructor to determine the correct angles to draw the lines. The texture class in which the lines intersect is the texture class of your soil.

# Practical Ecology 2022-2023

---

## ✓ Analysis of soil mechanics with sieve method

1. Collecting the soils and dried for 72 hours
2. Crushed soil by Mortar to break up all the coarse soil in the sample
3. Take 200 gram of sample and placed it in a sieve to allow the passage of soil particles as follows,
  - A. The first sieve with mesh size 2mm which prevents the particles has a diameter more than 2mm from passing
  - B. Second sieve with mesh size 0.2 mm which gathered the fine sand
  - C. Third sieve with mesh size 0.002 mm which gathered the silt
  - D. Forth sieve with mesh size less than 0.002 which gathered the clay
4. Weight each type of soil and calculate the percentage according to the first weight (200 gram)
5. Describe the texture of soil using the triangular diagram by using the proportion of each sand, silt, clay as in the following example ,

The proportion of sand 40%

The proportion of silt 30%

The proportion of clay 30%

To read the triangular chart draw a line from the silt line parallel with clay line, and from clay parallel with the sand line and from the sand parallel to the silt line using recorded percentages above. Finally, notice the zone on the chart, which represents the intersection of the three-point line and records the result. In this example was clay loam.

## **Lab 9**

### **Measurement of productivity**

## Practical Ecology 2022-2023

---

*Primary production*:— refers to the total organic matter produced as a result of photosynthesis and nutrient uptake from the soil. The ‘primary’ preceding production is used to distinguish it from production at the second trophic level (consumption) (The conversion of plant organic matter into the body tissue of animals). Primary production is referred to as *gross primary production* when all organic matter including that used in metabolism is taken into consideration. Often, however, it is *net primary production* which can easily be measured. The latter is sometimes called *apparent photosynthesis*.

Net primary production is defined as the quantity of organic matter produced over a period of time, less that used in metabolic processes.

### *1. Methods Used in Measuring Productivity*

#### *A. Direct method*

The direct method is based on biomass determined by harvesting and weighing of all organic matter present in a unit area of the ecosystem.

#### *B. Indirect methods:*

##### **1- Oxygen measurement :**

Primary productivity can be measured from the amount of oxygen consumed by a volume of water in a fixed period of time; water for which productivity is to be determined is enclosed in sealed white and dark bottles (bottle painted dark so light would not enter). DO (dissolved oxygen) measurement of water is made at the beginning of the immersion period. The two bottles are then immersed in the water body concerned at the level from which the water is taken. The phytoplankton and other elements in the water produce oxygen in the water bottle, but some oxygen disappears due to respiration. The latter is measured from the readings of dark bottle, where only respiration takes place. Thus from the oxygen produced by photosynthesis of enclosed organism (representing a sample of the water body) can be known. However this oxygen production indicates net primary productivity only. From the DO difference in dark bottle oxygen consumed by the enclosed organisms can be obtained



## Practical Ecology 2022-2023

---

and when this respiration value is added to the oxygen production in the white bottle, a value for gross primary productivity is obtained.

### **2. Diel method:**

Estimates of primary productivity can also be made from diel changes in oxygen, considering the day as the light bottle and night as the dark bottle. The increase in DO in the day time is net primary production and the decrease in the night is half the diel respiration. This can be added on to the day-time gain to get daily gross photosynthesis. This volume should normally be corrected for the loss or gain in oxygen due to concentration gradient over the day.

### **3. C<sub>14</sub> method:**

The most accurate method for determining productivity is the method of using radioactive carbon (C<sub>14</sub>) added as carbonate. Labelled carbonate is added into a bottle containing water with the phytoplankton and other organisms and after a short period of time the plankton is separated, dried and plancheted in addition to the radioactive carbon fixed can be measured from the radioactive counts made. The productivity measured thus is net primary productivity as the carbon fixed in the tissues only are measured here. In selecting a water body for aquaculture measurement of primary productivity and estimation of potential yield would be of great assistance in planning the culture activity. This would be specially done while evaluating water bodies (natural or man-made) for stocking (in extensive culture) and also for cage and enclosure culture.

### **4. pH.**

During photosynthesis under favorable environmental conditions, the rate of CO<sub>2</sub> uptake may be 10 to 20 times the normal rate of respiratory CO<sub>2</sub> release. As the uptake of CO<sub>2</sub> (or any of the other species of inorganic carbon) will affect the hydrogen ion concentration, it is possible to estimate the rate of CO<sub>2</sub> uptake by measurement of the pH of the surrounding

## Practical Ecology 2022-2023

---

medium. This method is not very useful in the marine environment as the large reservoir of inorganic carbon (25-30 mg inorganic C/liter) makes the method relatively insensitive.

### **5. Nutrient Uptake**

By measurement of the uptake of essential inorganic nutrients (e.g. nitrogen substrates and phosphate) , coupled with assumptions regarding the carbon/nitrogen or carbon/phosphorus ratios in the phytoplankton cells, it is possible to estimate the rate of  $CO_2$  reduction. This method cannot be very precise because of the relatively large variations in ratios of elements in cellular material, but it has been used to advantage in estimating large-scale productivity of water masses.

### **6. Chlorophyll.**

The basis for estimating productivity from chlorophyll measurements is that assimilation values (the rate of  $CO_2$  reduction per unit chlorophyll per unit time) are quite similar for phytoplankton in most parts of the oceans. With our better understanding of the effects of temperature , light, and nutrients on the rate of photosynthesis, it is possible to estimate productivity even in those environments where conditions are not optimum for photosynthesis.

### **Solar soil sterilization (an environmentally-friendly alternative)**

Concern over environmental hazards and public awareness were increased on human health issues that caused by pesticides. These pesticides have directed much attention to alternative practices for chemical pest control. Soil solarization or “solar heating” is a non-chemical disinfestation practice; it could also increase the soil mineral nutrients and may decrease the crop fertilization requirements, those results in improved plant growth and yield. Solarization was originally developed to control soil-borne pathogens as first reported by Katan *et al.* (1976). It was soon found as an effective treatment against a range of other soil-borne pests and weeds including: more than 40 fungal plant pathogens, a few bacterial pathogens, 25 species of nematodes and many weed.

#### ✓ *Principles of soil solarization*

The basic principle of solarization depends on the concept that raising the moist soil temperature to a lethal level could directly effects on the viability of certain organisms. The heating process also induces other environmental and biological changes to the soil that indirectly affect the soil-borne pests as well as survival of beneficial organisms. The values of the maximum soil temperature and amount of heat accumulated (duration \* temperature) determine the potential of the thermal killing effect on soil-borne pests and weed seeds. In general, all types of plastic transparent sheets commonly used in agriculture are proper for solarization purposes. Part of the solar radiation is transmitted through the plastic transparent, absorbed by the soil surface and transformed to conserved heat. Some plastic sheets differ in their chemical and physical properties such as thickness, colour and wavelength transmission, UV protection and durability. The plastic sheet largely prevents the escape of long-waves radiation and water evaporation from the soil to the atmosphere, consequently exerting a greenhouse effect. In addition, the water vapors accumulated on the inner surface of the plastic sheet further enhance the greenhouse effect, resulting in higher soil temperatures.

#### ✓ *The important of soil solarization*

## Practical Ecology 2022-2023

---

Historically, soil sterilization was used to control soil borne diseases. These sterilization processes used different methods such as

1. Sterilization by using chemicals (Pesticides) before planting.
2. Sterilization using steam (steaming) this method could be applied using special pipe goes through the soil steaming to kill microbes.
3. Atomic radiation method like using (x-ray).

However, these methods are more expensive and might be caused pollution, so it's developed to use the solar energy. Sun rays incident on soil surface are usually consist of short waves of energy, these waves becomes long waves when it's suffering from refraction in the atmosphere because the clouds or because the glass of green house in different degree according to its color. The general benefit of soil sterilization using solar energy could be summarized in following:

1. Preserving soil moisture to reduce required irrigation water due to evaporation reduction.
- 2.Reduction of soil salts cotenants.
3. Increasing organic materials in which provide the important elements of plant growing.
4. Reduction of pH
5. Some soil particles stick to each other's with nutrition materials in which increase its density by decreasing temperature.
6. Inhibition of plant pathological causes like Bacteria, fungi and weed seeds.

### ✓ *Soil solarization in application*

We can divided this method to the following parts

#### **a. Field work:**

This process is best done during summer time, when the day temperature reading is at its peak. As expected, solar sterilization of different soil may take longer time in cold regions.

## Practical Ecology 2022-2023

---

First of all, determine the area you want to be sterilized and dig a small trench approximately 3 inches deep around the perimeter of the area to be treated.

1. Get rid of those unwanted weeds and remove large debris.
2. Water the soil thoroughly, making sure that water penetrates to 18 inches depth, so the soil is better able to conduct heat.
3. Following this, cover the whole area with a transparent plastic sheet. In order to fix the plastic at place, you can lay down large bricks in the middle and sides.
4. Leave the plastic for at least 4 weeks period. But, if the climate in your area is cold, extend the sterilization period to 1½ - 2 months.
5. One layer of clear plastic on a sunny day heats the soil to 119-degrees F. at a depth of 4-inches.
6. Two layers of clear plastic heats the same soil to 140-degrees at a depth of 4-inches.
7. Heating soil to 107-degrees at a depth of 12 inches kills 98-percent of Fusarium oxysporum
8. For effective solarization to take place, the recommended temperature is 114° F. You can check the temperature inside the plastic sheet, and see if it reaches the desired temperature range or not. Accordingly, you can adjust the solar sterilization period.